

Pressure Controls

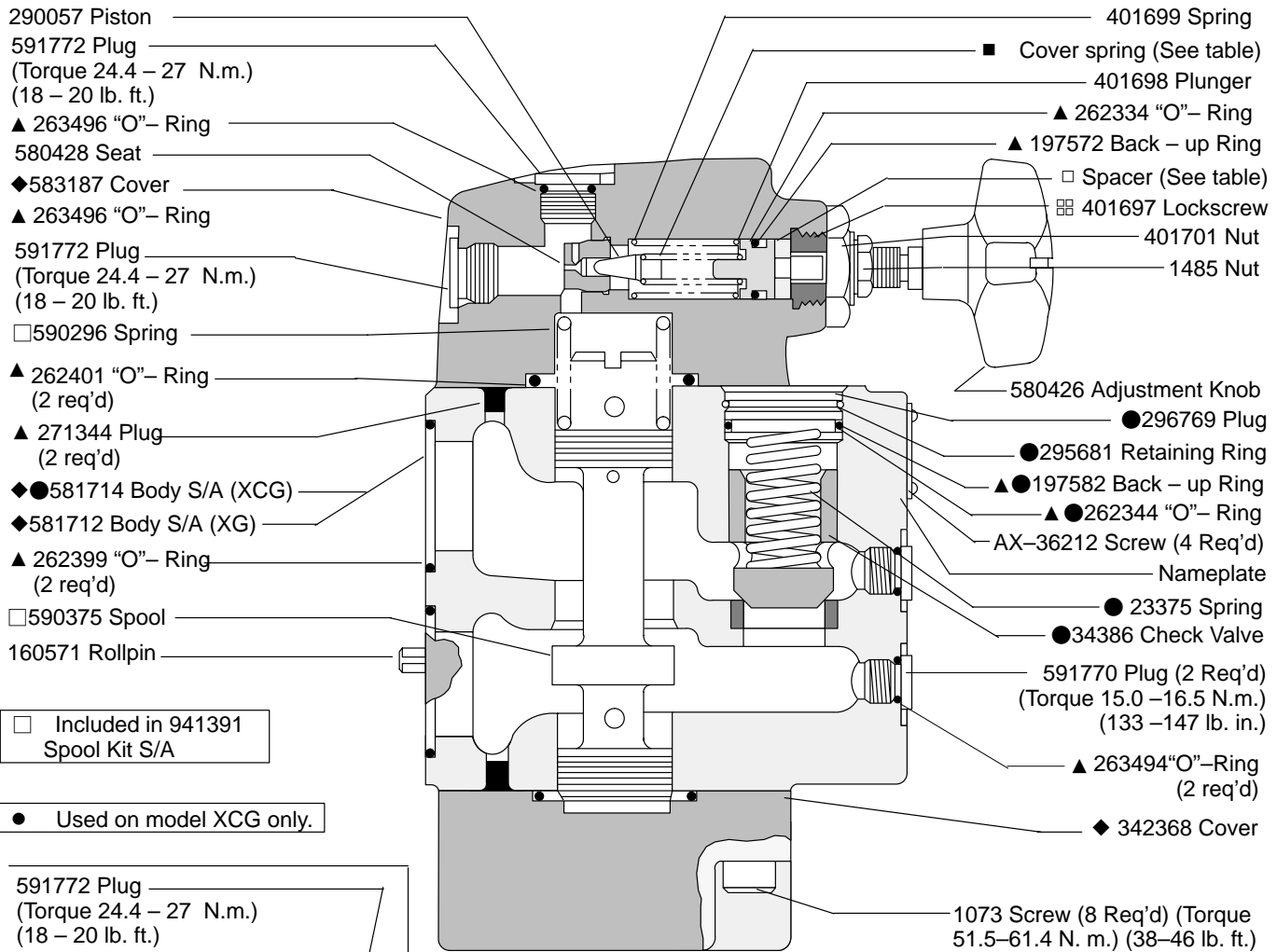

Pressure Reducing Valves

X(C)G - H10 - * - 30



□ Included in 941391 Spool Kit S/A

● Used on model XCG only.

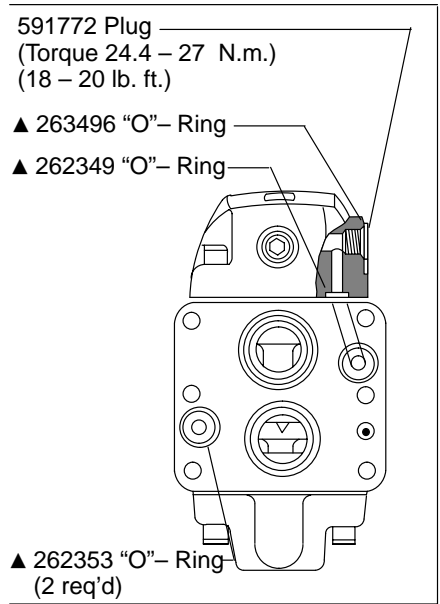

▲ Service all units with F3 seal kit 919852.

▣ **NOTE**
 Install lockscrew W/Stepped O. D. end toward spacer or plunger as shown.

◆ Not available for sale.

Model	Cover spring	Spacer	Pressure range P.S.I.
X(C)G-H10-1-30	2280	—	1000
X(C)G-H10-2-30	583937	—	2000
X(C)G-H10-3-30	401700	386715	2850

Model Code

(F3) - X(C)G - H 10 * -30

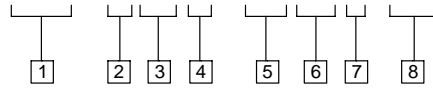

1 Seals

F3 - Seals for mineral oil and fire resistant fluids

2 Model Series

X - Pressure reducing valve

3 Integral Check Valve

Omitted - No check valve

4 Manifold or Subplate Mounted

5 Nominal Valve Size

10 - 1-1/4 inch

6 High Flow

H - 140 USgpm

7 Maximum Adjustable Pressure

- 1** - 1000 PSI
- 2** - 2000 PSI
- 3** - 2800 PSI

8 Design

For satisfactory service life of these components, use full flow filtration to provide fluid which meets ISO cleanliness code 18/15 or cleaner. Selections from Eaton OFF, OFR and OFRS filter series are recommended.