

**EATON**

**Vickers**

**Series AM/MM/WM Mill Type Cylinders**



**VICKERS®**

## Table of Contents

Design Features and Specifications .....	2	WM15 Trunnion Mount .....	11
How to Order .....	3-5	WM24 Basic No Mount .....	12
Mounting Dimensions .....	6-13	Rod End Selection .....	13
WM01 Side Lug Mount .....	6	Mounting Accessories .....	14
WM09 Head Rectangular Mount .....	7	Swivel Pin.....	14
WM10 Clevis Mount .....	8	Rod Eye.....	14
WM11 Spherical Bearing Mount .....	9	Eye Bracket.....	14
WM14 Cap Rectangular Mount .....	10	Rod Clevis.....	14

## Design Features and Specifications

### Specifications

**Bore Sizes:** 2" - 16"

**Pressure Ratings:**

MM- 2,000 psi Nominal Hydraulic Service

WM- 3,000 psi Nominal Hydraulic Service

AM- 250 psi Pneumatic Service

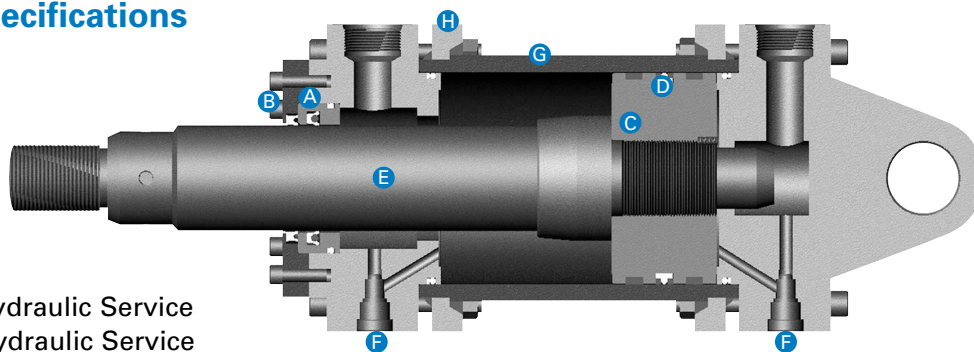

### A Heavy Duty Rod Cartridge

- SAE 660 bronze rod cartridge is pilot-fitted into the head and incorporates inboard and outboard bearing areas.
- Aluminum bronze material available as an option.

### B Rod Seal and Wiper

Hydraulic:

- High durometer urethane mechanically loaded rod seal with a double lip rod wiper provides contamination exclusion and abrasion resistance.
- High durometer double lip rod wiper.
- Metallic rod scraper available as an option.
- Other rod sealing and wiping systems are available as an option.

Pneumatic:

- High quality nitrile U-cup rod seal and double-lipped wiper.
- Other rod sealing and wiping systems are available as an option.

### C Secured Piston

- One piece pilot-fitted ductile iron material.
- Secured to the piston rod by set screws staked in place.
- Steel pistons available as an option with wear bands or bronze overlay.

### D Piston Seals

Hydraulic:

- Bi-directional nitrile piston seal with outboard wearbands prevents pressure traps and protects against sideloading.
- Other sealing configurations are available as an option.

Pneumatic:

- High quality nitrile U-cup piston seals.
- Other sealing configurations are available as an option.

### E High Yield Piston Rod

- High yield, turned, ground and polished C1045/50 microalloy steel.
- Hard chrome plated a minimum of .001" diametrically.
- Heavier plating available as an option, in addition to various types of stainless steel and chrome over nickel plated rod material.

### F Cushions

- Adjustable design allows for smooth deceleration.
- Ball check design allows for a smooth breakaway from cushion.

### G High Yield Steel Tubing

Hydraulic:

- High yield strength steel.
- All tubes honed after welding of flanges.
- Chrome-plated bores available as an option.

Pneumatic:

- High yield strength steel.
- Tubes honed & chrome-plated to .001" minimum diametrically.
- Heavier plating available as an option.

### H Body Flanges

- Steel construction.
- Grade 8 bolts used for assembly with hardened steel washers.
- Hydraulic: Flanges threaded or welded to the body tube for maximum strength and durability.
- Pneumatic: Split ring and groove design secures flanges in standard duty applications; threaded or welded flanges are available for heavier duty applications.

# How to Order

---

## Standard Cylinders

Eaton has created an easy system for ordering Vickers Series AM/MM/WM Cylinders. This system has been developed to improve our service to you. The model code consists of sixteen alpha-numeric digits which fully describe the most common standard options offered on Series AM/MM/WM cylinders.

To specify your Series AM/MM/WM cylinder, review the following pages for a full description of each option available and select the desired code.

This model code system will:

- **Simplify the re-order process.**  
Each Vickers cylinder is assigned a sixteen digit model code. That code is unique to a particular cylinder description. That way, when you re-order your Series AM/MM/WM cylinder, you're assured of exactly the same top quality cylinder design.
- **Improve identification.**  
Every cylinder has its sixteen digit model code clearly marked on the product. Each sixteen digit code completely describes a specific cylinder. This allows seals and replacement components to be easily identified in the field.
- **Facilitate communications.**  
This fully descriptive model code system allows you to work directly with your local Eaton sales engineer to identify and service your Vickers cylinder.

### NOTE

See pages 4 and 5 for a summary of model code options.

## Custom Cylinders

### New Cylinders

Although the model code has been arranged to cover the vast majority of available options, there will be occasions when you require an option which cannot be coded. When specifying such an option, enter an "X" for the appropriate item in the sixteen digit model code, then describe your requirements. For example, if you have an application which requires a custom thread on the end of the piston rod, enter an "X" for item 7. Then add a full description at the end of the model code, such as "With 3.25 inch total rod projection and M22 x 1.5 thread 1.375 inches long." The cylinder will then be given a unique five digit design number on receipt of order (as explained below).

### Replacement Cylinders

Every custom Vickers cylinder is assigned a unique design number. This number is contained in the last five digits of the sixteen digit model code, and item 12 is always an alpha character. In other words, the "Stroke" and "Extra-Rod Projection" locations (items 12 through 16) become the "Design Number" items for custom cylinders. When ordering a replacement cylinder, simply give the sixteen digit model code or the five digit design number to your local Vickers Cylinder Sales representative.

### Replacement Parts

Each design number is stored in a quick retrieval computerized storage system. This gives our field sales representatives rapid access to assist you in identifying and specifying genuine Vickers replacement parts.

# How to Order Series AM/MM/WM Cylinders

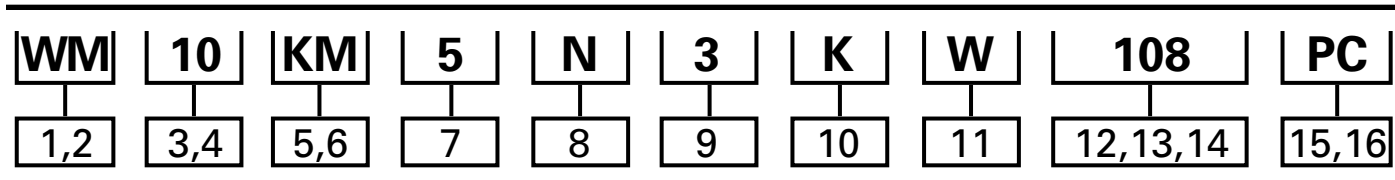

1,2 Series		5,6 Bore & Rod diameter			7 Rod end type	
<b>WM</b> - 3000 psi Hydraulic Mill Cylinder <b>MM</b> - 2000 psi Hydraulic Mill Cylinder <b>AM</b> - 250 psi Pneumatic Mill Cylinder		<b>Code</b>	<b>Bore</b>	<b>Rod</b>	<b>Code</b>	<b>Rod End Style</b>
		DE	2	1	2	Short
		DH	2	1-3/8		Female UN Thread
		FH	3	1-3/8	5	Small Male UN Thread
		FL	3	1-3/4		
		FM	3	2		
		HL	4	1-3/4	6	Plain-No Attachment
		HM	4	2		
		HP	4	2-1/2		
		KM	5	2	9	Intermediate Male UN Thread
		KP	5	2-1/2		
		KV	5	3-1/2		
		LP	6	2-1/2	G	Grooved End
		LU	6	3		
		LW	6	4		
		MU	7	3	K	Extended Small Male UN Thread
		MV	7	3-1/2		
		MZ	7	5		
		NV	8	3-1/2	M	Extended Int. Male UN Thread
		NW	8	4		
		N1	8	5-1/2		
		RW	10	4		
		RZ	10	5		
		R1	10	5-1/2		
		R4	10	7		
		S1	12	5-1/2		
		S4	12	7		
		S6	12	8		
		T4	14	7		
		T7	14	9		
		U7	16	9		
		U8	16	10		

8 Seals	
Code	Application Type
<b>N</b>	Normal
<b>L</b>	Low Friction
<b>T</b>	High Temperature
<b>C</b>	Classic (Chevron/ C.I. Rings)





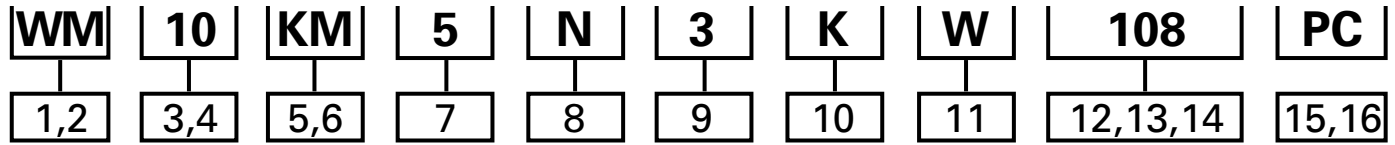

All dimensions in inches.

# How to Order Series AM/MM/WM Cylinders



### 9 Ports

For maximum reliability, SAE ports are recommended.

Code	Port Style
1 NPTF	
2 Oversize NPTF	
3 SAE/UN Straight thread O-ring	
4 Oversize SAE/UN O-ring	
7 BSPP	
8 Oversize BSPP	

### 11 Cushion Location

Code	Head	Cap
A	-	-
B	-	1
C	-	2
D	-	3
E	-	4
F	1	-
G	2	-
H	3	-
J	4	-
K	1	1
L	1	2
M	1	3
N	1	4
P	2	1
R	2	2
S	2	3
T	2	4
U	3	1
V	3	2
W	3	3
Y	3	4
1	4	1
2	4	2
3	4	3
4	4	4

### 15,16 Enter applicable code for either:

**Extra Rod Protection ("C" dimension)**

Item 15 indicates inches from 0 through 9.

Item 16 indicates fractions on an inch per codes shown for item 14.

**-OR-**

**Air bleed, gland drain or proximity sensor positions**

Item 15 indicates air bleeds (H), gland drains (G), or proximity sensors (P).

Item 16 indicates location of air bleeds, gland drain\* or proximity switches as shown in item 10 when viewing cylinder from head end (or mounting end of double rod end cylinders).

"-" in table indicates no air bleed or proximity sensor.

### 10 Port Location

Ports are located as shown below when viewing cylinder from head end (mounting end of double rod cylinder). Some mounting styles have port location restrictions.

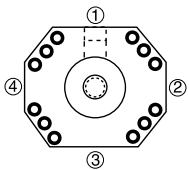

Code	Head	Cap
K	1	1
L	1	2
M	1	3
N	1	4
P	2	1
R	2	2
S	2	3
T	2	4
U	3	1
V	3	2
W	3	3
Y	3	4
1	4	1
2	4	2
3	4	3
4	4	4

### 12,13,14 Cylinder Stroke

Items 12 & 13 indicate total stroke length from 1 through 99 inches.

Item 14 indicates fractions of an inch as follows:

Code	Fraction	Code	Fraction
0	0	8	1/2
1	1/16	9	9/16
2	1/8	A	5/8
3	3/16	B	11/16
4	1/4	C	3/4
5	5/16	D	13/16
6	3/8	E	7/8
7	7/16	F	15/16

Code	Head	Cap
A	-	-
B	-	1
C	-	2
D	-	3
E	-	4
F	1	-
G	2	-
H	3	-
J	4	-
K	1	1
L	1	2
M	1	3
N	1	4
P	2	1
R	2	2
S	2	3
T	2	4
U	3	1
V	3	2
W	3	3
Y	3	4
1	4	1
2	4	2
3	4	3
4	4	4

\* Gland drain is used on head end only

# 01 Side Lug Mount

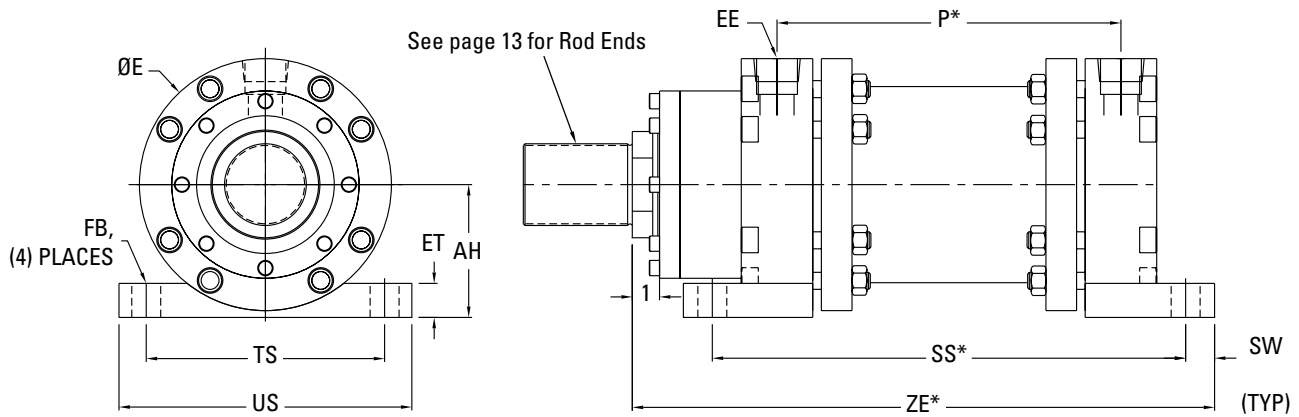

## AM01/MM01

BORE	ROD	E	BSP or NPT	SAE	P*	ZE*	SS*	SW	FB	US	TS	ET	AH
			EE	EE									
2	1 1.375	3.88	1/2	#8	3.75	8.13	6.13	.38	.41	5.06	4.25	.63	2.188
3	1.375 2	5.19	1/2	#8	4.25	8.88	7.00	.50	.56	6.56	5.56	.75	2.844
4	1.75 2.5	6.25	3/4	#12	4.50	10.00	7.50	.63	.69	7.88	6.63	1.00	3.375
5	2 3.5	7.88	3/4	#12	5.50	12.88	9.24	.75	.81	9.75	8.25	1.13	4.188
6	2.5 4	9.25	1	#16	6.25	14.88	10.88	1.00	1.06	11.63	9.63	1.50	4.875
7	3 5	10.75	1-1/4	#20	6.38	16.00	11.38	1.13	1.19	13.25	11.13	1.75	5.625
8	3.5 5.5	12.00	1-1/2	#24	7.75	18.13	13.75	1.25	1.31	14.88	12.38	1.88	6.250
10	4 5.5	14.94	2	#32	9.25	20.44	15.75	1.50	1.56	18.31	15.31	2.25	7.781
12	5.5 7	17.19	2-1/2	#32	10.44	23.25	17.75	1.75	1.81	21.06	17.56	2.63	9.125
14	7 9	19.50	2-1/2	#32	10.69	25.25	18.50	2.00	2.06	23.88	19.88	3.00	10.500
16	9 10	23.38	3	#32	11.19	28.38	20.38	2.25	2.31	28.25	23.75	3.38	12.438

## WM01 3000 PSI

BORE	ROD	E	BSP or NPT	SAE	P*	ZE*	SS*	SW	FB	US	TS	ET	AH
			EE	EE									
3	1.375 2	5.19	1/2	#8	5.38	11.50	8.13	.50	.56	6.56	5.56	.75	2.844
4	1.75 2.5	6.50	3/4	#12	5.75	12.19	8.75	.63	.69	8.13	6.88	1.00	3.500
5	2 3.5	7.88	3/4	#12	7.00	15.25	10.75	.75	.81	9.75	8.25	1.13	4.188
6	2.5 4	9.25	1	#16	7.94	17.56	12.56	1.00	1.06	11.63	9.63	1.50	4.875
7	3 5	10.75	1-1/4	#20	8.63	19.63	13.50	1.13	1.19	13.38	11.13	1.75	5.625
8	3.5 5.5	12.38	1-1/2	#24	10.25	22.69	16.25	1.25	1.31	15.38	12.75	1.88	6.438
10	4 5.5	14.94	2	#32	10.50	25.44	17.00	1.50	1.56	18.31	15.31	2.25	7.781
12	5.5 7	17.50	2-1/2	#32	11.31	27.88	18.63	1.75	1.81	21.63	17.88	2.63	9.125
14	7 9	20.38	2-1/2	#32	11.56	29.75	19.38	2.00	1.06	24.75	20.75	3.00	10.688
16	9 10	23.38	3	#32	12.50	33.75	21.25	2.25	2.31	28.25	23.75	3.38	12.438

\*Add stroke to these dimensions

All dimensions in inches

# 09 Head Rectangular Mount

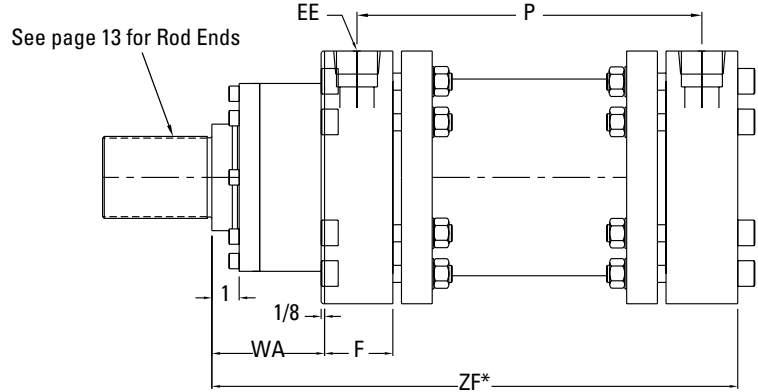
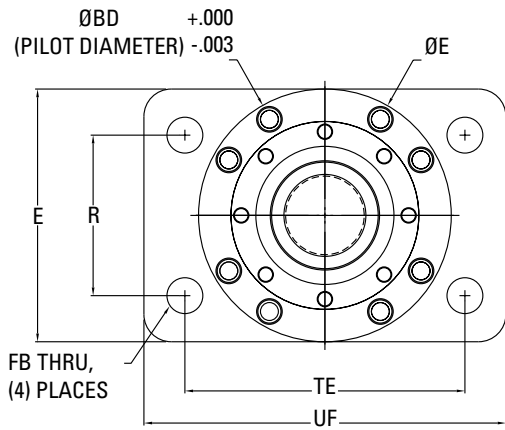

## AM09/MM09

BORE	ROD	E	BSP or NPT		SAE		P*	ZF*	F	FB	R	TE	UF	BD	WA
			EE	EE											
2	1 1.375	3.88	1/2	#8	3.75	7.38	1.50	.41	3.13	4.25	5.00	3.875	2.13		
3	1.375 2	5.19	1/2	#8	4.25	7.88	1.63	.56	4.19	5.75	6.75	5.187	2.00		
4	1.75 2.5	6.25	3/4	#12	4.50	8.75	1.63	.69	5.00	6.94	8.19	6.250	2.63		
5	2 3.5	7.88	3/4	#12	5.50	11.38	2.13	.81	6.38	8.69	10.19	7.875	3.75		
6	2.5 4	9.25	1	#16	6.25	12.88	2.50	1.06	7.25	10.31	12.31	9.250	4.13		
7	3 5	10.75	1-1/4	#20	6.38	13.63	2.50	1.19	8.38	11.94	14.19	10.750	4.75		
8	3.5 5.5	12.00	1-1/2	#24	7.75	15.63	3.38	1.31	9.50	13.94	15.81	12.000	4.50		
10	4 5.5	14.94	2	#32	9.25	17.44	3.38	1.56	11.94	16.50	19.50	14.937	4.81		
12	5.5 7	17.19	2-1/2	#32	10.44	19.75	3.69	1.81	13.69	19.00	22.50	17.187	5.63		
14	7 9	19.50	2-1/2	#32	10.69	21.50	3.69	2.06	15.50	21.56	25.56	19.500	7.13		
16	9 10	23.38	3	#32	11.19	23.88	4.13	2.31	18.88	25.69	30.19	23.000	8.13		

## WM09 3000 PSI

BORE	ROD	E	BSP or NPT		SAE		P*	ZF*	F	FB	R	TE	UF	BD	WA
			EE	EE											
3	1.375 2	5.19	1/2	#8	5.38	10.50	1.63	.56	4.19	5.75	6.75	5.187	3.50		
4	1.75 2.5	6.50	3/4	#12	5.75	10.19	1.63	.69	5.25	7.19	8.44	6.250	3.56		
5	2 3.5	7.88	3/4	#12	7.00	13.75	2.13	.81	6.38	8.69	10.19	7.875	4.63		
6	2.5 4	9.25	1	#16	7.94	15.56	2.50	1.06	7.25	10.31	12.31	9.250	5.13		
7	3 5	10.75	1-1/4	#20	8.63	17.38	2.50	1.19	8.50	11.94	14.19	10.750	6.25		
8	3.5 5.5	12.38	1-1/2	#24	10.25	20.19	3.38	1.31	9.88	13.69	16.19	12.000	6.56		
10	4 5.5	14.94	2	#32	10.50	21.94	3.38	1.56	11.94	16.50	19.50	14.937	8.56		
12	5.5 7	17.50	2-1/2	#32	11.31	24.38	3.69	1.81	14.00	19.31	22.81	17.187	9.38		
14	7 9	20.38	2-1/2	#32	11.56	25.75	3.69	2.06	16.38	22.44	26.44	19.500	10.50		
16	9 10	23.38	3	#32	12.50	29.25	4.13	2.31	18.88	25.69	30.19	23.000	12.63		

\*Add stroke to these dimensions

All dimensions in inches

# 10 Clevis Mount

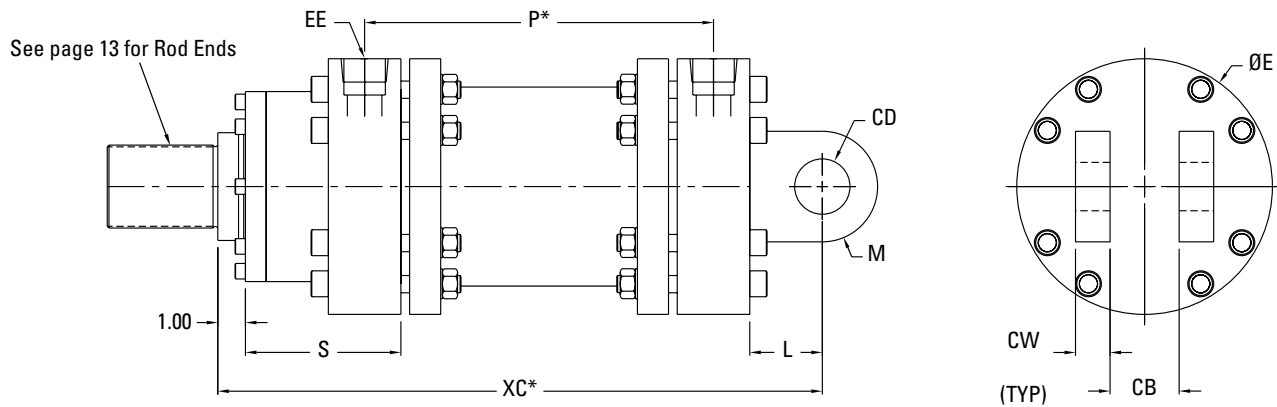

## AM10/MM10

			BSP or NPT	SAE									
BORE	ROD	E	EE	EE	P*	XC*	S	M	CD	L	CW	CB	
2	1 1.375	3.88	1/2	#8	3.75	8.63	3.63	.75	.750	1.25	.63	1.25	
3	1.375 2	5.19	1/2	#8	4.25	9.38	3.63	1.00	1.000	1.50	.75	1.50	
4	1.75 2.5	6.25	3/4	#12	4.50	10.88	4.25	1.38	1.375	2.12	1.00	2.00	
5	2 3.5	7.88	3/4	#12	5.50	13.63	5.88	1.75	1.750	2.25	1.25	2.50	
6	2.5 4	9.25	1	#16	6.25	15.38	6.63	2.00	2.000	2.50	1.25	2.50	
7	3 5	10.75	1-1/4	#20	6.38	16.63	7.25	2.50	2.500	3.00	1.50	3.00	
8	3.5 5.5	12.00	1-1/2	#24	7.75	18.88	7.88	3.00	3.000	3.25	1.50	3.00	
10	4 5.5	14.94	2	#32	9.25	21.44	8.19	3.50	3.500	4.00	2.00	4.00	
12	5.5 7	17.19	2-1/2	#32	10.44	24.25	9.31	4.00	4.000	4.50	2.25	4.50	
14	7 9	19.50	2-1/2	#32	10.69	27.25	10.81	5.00	5.000	5.75	3.00	6.00	
16	9 10	23.38	3	#32	11.63	30.88	12.25	6.00	6.000	7.00	3.50	7.00	

## WM10 3000 PSI

			BSP or NPT	SAE									
BORE	ROD	E	EE	EE	P*	XC*	S	M	CD	L	CW	CB	
3	1.75 2	5.19	1/2	#8	5.38	12.00	5.13	1.00	1.000	1.50	.75	1.50	
4	2 2.5	6.50	3/4	#12	5.75	13.06	5.19	1.38	1.375	2.13	1.00	2.00	
5	2.5 3.5	7.88	3/4	#12	7.00	16.00	6.75	1.75	1.750	2.25	1.25	2.50	
6	3 4	9.25	1	#16	7.94	18.06	7.63	2.00	2.000	2.50	1.25	2.50	
7	3.5 5	10.75	1-1/4	#20	8.63	20.38	8.75	2.50	2.500	3.00	1.50	3.00	
8	4 5.5	12.38	1-1/2	#24	10.25	23.44	9.94	3.00	3.000	3.25	1.50	3.00	
10	5 7	14.94	2	#32	10.50	26.44	11.94	3.50	3.500	4.00	2.00	4.00	
12	5.5 8	17.50	2-1/2	#32	11.31	28.88	13.06	4.00	4.000	4.50	2.25	4.50	
14	7 9	20.38	2-1/2	#32	11.56	31.50	14.19	5.00	5.000	5.75	3.00	6.00	
16	9 10	23.38	3	#32	12.50	36.25	16.75	6.00	6.000	7.00	3.50	7.00	

\*Add stroke to these dimensions

All dimensions in inches



# 11 Spherical Bearing Mount

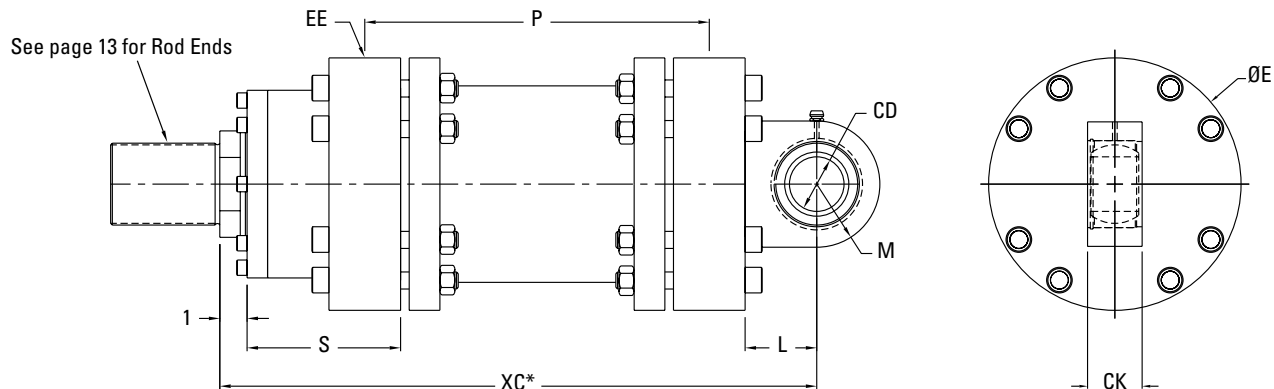

## AM11/MM11

BORE	ROD	E	BSP or NPT		P*	XC*	S	M	CD	L	CK
			EE	SAE							
2	1 1.375	3.88	1/2	#8	3.75	8.63	3.63	1.25	.750	1.25	.56
3	1.375 2	5.19	1/2	#8	4.25	9.38	3.63	1.63	1.000	1.50	1.00
4	1.75 2.5	6.25	3/4	#12	4.50	10.88	4.25	1.75	1.375	2.13	1.50
5	2 3.5	7.88	3/4	#12	5.50	13.63	5.88	2.50	1.750	2.25	1.75
6	2.5 4	9.25	1	#16	6.25	15.38	6.63	2.88	2.000	2.50	2.00
7	3 5	10.75	1-1/4	#20	6.38	16.63	7.25	3.38	2.500	3.00	2.50
8	3.5 5.5	12.00	1-1/2	#24	7.75	18.88	7.88	3.88	3.000	3.25	3.00
10	4 5.5	14.94	2	#32	9.25	21.44	8.19	5.50	3.500	4.00	3.19
12	5.5 7	17.19	2-1/2	#32	10.44	24.25	9.31	6.00	4.000	4.50	3.50
14	7 9	19.50	2-1/2	#32	10.69	27.25	10.81	5.75	5.000	5.75	4.25
16	9 10	23.38	3	#32	11.63	30.88	12.25	7.50	6.000	7.00	4.63

## WM11 3000 PSI

BORE	ROD	E	BSP or NPT		P*	XC*	S	M	CD	L	CK
			EE	SAE							
3	1.75 2	5.19	1/2	#8	5.38	12.00	5.13	1.63	1.000	1.50	1.00
4	2 2.5	6.50	3/4	#12	5.75	13.06	5.19	1.75	1.375	2.13	1.50
5	2.5 3.5	7.88	3/4	#12	7.00	16.00	6.75	2.50	1.750	2.25	1.75
6	3 4	9.25	1	#16	7.94	18.06	7.63	2.88	2.000	2.50	2.00
7	3.5 5	10.75	1-1/4	#20	8.63	20.38	8.75	3.38	2.500	3.00	2.50
8	4 5.5	12.38	1-1/2	#24	10.25	23.44	9.94	3.88	3.000	3.25	3.00
10	5 7	14.94	2	#32	10.50	26.44	11.94	5.50	3.500	4.00	3.19
12	5.5 8	17.50	2-1/2	#32	11.31	28.88	13.06	6.00	4.000	4.50	3.50
14	7 9	20.38	2-1/2	#32	11.56	31.50	14.19	6.75	5.000	5.75	4.25
16	9 10	23.38	3	#32	12.50	36.25	16.75	7.50	6.000	7.00	4.63

\*Add stroke to these dimensions

All dimensions in inches

# 14 Cap Rectangular Mount

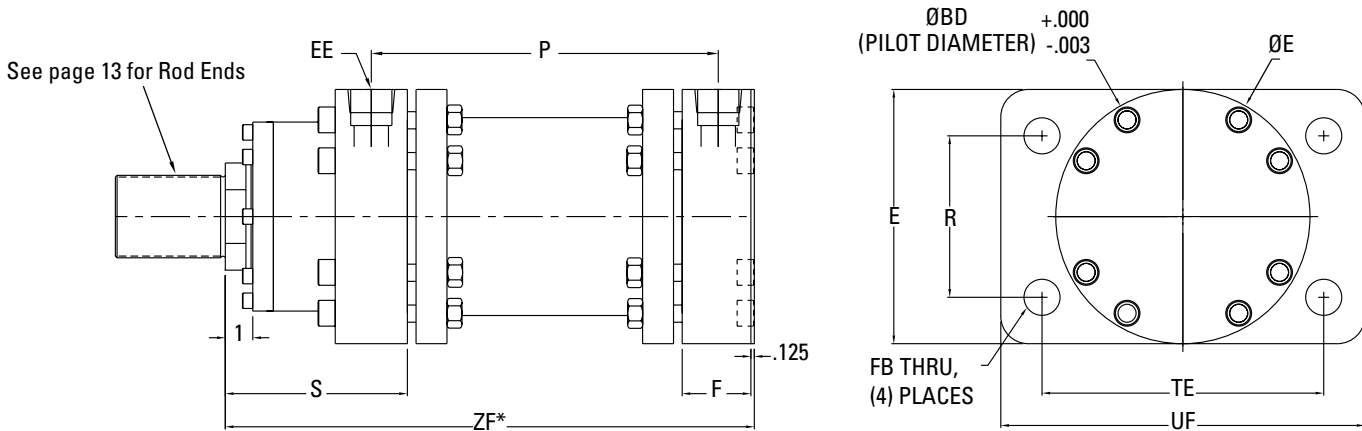

AM14/MM14		BSP or NPT	SAE										
BORE	ROD	E	EE	EE	P*	ZF*	F	FB	R	TE	UF	BD	S
2	1 1.375	3.88	1/2	#8	3.75	7.38	1.50	.41	3.13	4.25	5.00	3.875	3.63
3	1.375 2	5.19	1/2	#8	4.25	7.88	1.63	.56	4.19	5.75	6.75	5.187	3.63
4	1.75 2.5	6.25	3/4	#12	4.50	8.75	1.63	.69	5.00	6.94	8.19	6.250	4.25
5	2 3.5	7.88	3/4	#12	5.50	11.38	2.13	.81	6.38	8.69	10.19	7.875	5.88
6	2.5 4	9.25	1	#16	6.25	12.88	2.50	1.06	7.25	10.31	12.31	9.250	6.63
7	3 5	10.75	1-1/4	#20	6.38	13.63	2.50	1.19	8.38	11.94	14.19	10.750	7.25
8	3.5 5.5	12.00	1-1/2	#24	7.75	15.63	3.38	1.31	9.50	13.94	15.81	12.000	7.88
10	4 5.5	14.94	2	#32	9.25	17.44	3.38	1.56	11.94	16.50	19.50	14.937	8.19
12	5.5 7	17.19	2-1/2	#32	10.44	19.75	3.69	1.81	13.69	19.00	22.50	17.187	9.31
14	7 9	19.50	2-1/2	#32	10.69	21.50	3.69	2.06	15.50	21.56	25.56	19.500	10.81
16	9 10	23.38	3	#32	11.19	23.88	4.13	2.31	18.88	25.69	30.19	23.000	12.25

WM14 3000 PSI		BSP or NPT	SAE										
BORE	ROD	E	EE	EE	P*	ZF*	F	FB	R	TE	UF	BD	S
3	1.375 2	5.19	1/2	#8	5.38	10.50	1.63	.56	4.19	5.75	6.75	5.187	5.13
4	1.75 2.5	6.50	3/4	#12	5.75	10.19	1.63	.69	5.25	7.19	8.44	6.250	5.19
5	2 3.5	7.88	3/4	#12	7.00	13.75	2.13	.81	.38	8.69	10.19	7.875	6.75
6	2.5 4	9.25	1	#16	7.94	15.56	2.50	1.06	7.25	10.31	12.31	9.250	7.63
7	3 5	10.75	1-1/4	#20	8.63	17.38	2.50	1.19	8.50	11.94	14.19	10.750	8.75
8	3.5 5.5	12.38	1-1/2	#24	10.25	20.19	3.38	1.31	9.88	13.69	16.19	12.000	9.94
10	4 5.5	14.94	2	#32	10.50	21.94	3.38	1.56	11.94	16.50	19.50	14.937	11.94
12	5.5 7	17.50	2-1/2	#32	11.31	24.38	3.69	1.81	14.00	19.31	22.81	17.187	13.06
14	7 9	20.38	2-1/2	#32	11.56	25.75	3.69	2.06	16.38	22.44	26.44	19.500	14.19
16	9 10	23.38	3	#32	12.50	29.25	4.13	2.31	18.88	25.69	30.19	23.000	16.75

\*Add stroke to these dimensions

All dimensions in inches

# 15 Trunnion Mount

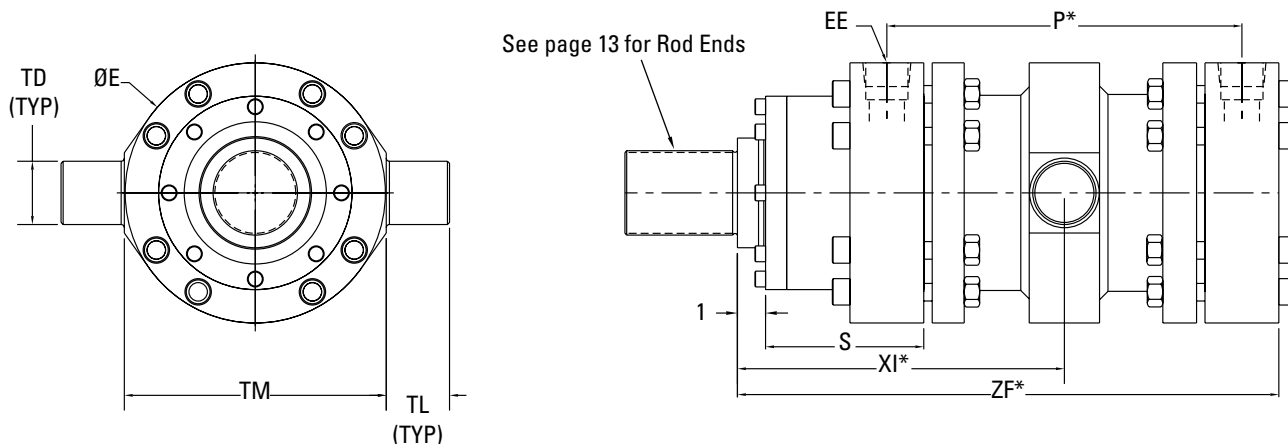

## AM15/MM15

BORE	ROD	E	BSP or NPT		SAE		P*	ZF*	S	TM	TL	TD
			EE	EE								
2	1 1.375	3.88	1/2	#8	3.75	7.38	3.63	3.94	1.25	1.250		
3	1.375 2	5.19	1/2	#8	4.25	7.88	3.63	5.25	1.38	1.375		
4	1.75 2.5	6.25	3/4	#12	4.50	8.75	4.25	6.31	1.75	1.750		
5	2 3.5	7.88	3/4	#12	5.50	11.38	5.88	7.94	2.00	2.000		
6	2.5 4	9.25	1	#16	6.25	12.88	6.63	9.94	2.25	2.250		
7	3 5	10.75	1-1/4	#20	6.38	13.63	7.25	10.81	2.38	2.375		
8	3.5 5.5	12.00	1-1/2	#24	7.75	15.63	7.88	12.06	2.50	2.500		
10	4 5.5	14.94	2	#32	9.25	17.44	8.19	15.00	3.00	3.000		
12	5.5 7	17.19	2-1/2	#32	10.44	19.75	9.31	17.25	3.50	3.500		
14	7 9	19.50	2-1/2	#32	10.69	21.50	10.81	19.56	4.50	4.500		
16	9 10	23.38	3	#32	11.19	23.88	12.25	23.44	5.00	5.000		

## WM15 3000 PSI

BORE	ROD	E	BSP or NPT		SAE		P*	ZF*	S	TM	TL	TD
			EE	EE								
3	1.75 2	5.19	1/2	#8	5.38	10.50	5.13	5.25	1.50	1.500		
4	2 2.5	6.50	3/4	#12	5.75	10.81	5.19	6.56	1.75	1.750		
5	2.5 3.5	7.88	3/4	#12	7.00	13.75	6.75	7.94	2.25	2.250		
6	3 4	9.25	1	#16	7.94	15.56	7.63	9.31	2.50	2.500		
7	3.5 5	10.75	1-1/4	#20	8.63	17.38	8.75	10.81	3.00	3.000		
8	4 5.5	12.38	1-1/2	#24	10.25	20.19	9.94	12.44	3.50	3.500		
10	5 7	14.94	2	#32	10.50	21.94	11.94	15.00	4.00	4.000		
12	5.5 8	17.50	2-1/2	#32	11.31	24.38	13.06	17.56	5.00	5.000		
14	7 9	20.38	2-1/2	#32	11.56	25.75	14.19	20.44	5.50	5.500		
16	9 10	23.38	3	#32	12.50	29.25	16.75	23.44	6.50	6.500		

\*Add stroke to these dimensions

All dimensions in inches

## 24 Basic No Mount

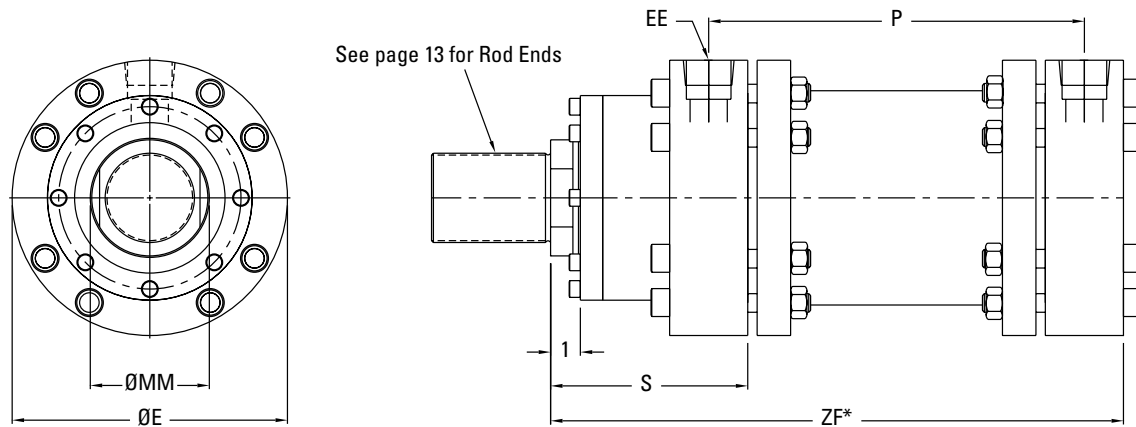

### AM24/MM24

BORE	ROD	E	BSP or NPT	SAE	P*	ZF*	S
2	1 1-3/8	3.88	1/2	#8	3.75	7.38	3.63
3	1-3/8 2	5.19	1/2	#8	4.25	7.88	3.63
4	1-3/4 2-1/2	6.25	3/4	#12	4.50	8.75	4.25
5	2 3-1/2	7.88	3/4	#12	5.50	11.38	5.88
6	2-1/2 4	9.25	1	#16	6.25	12.88	6.63
7	3 5	10.75	1-1/4	#20	6.38	13.63	7.25
8	3-1/2 5-1/2	12.00	1-1/2	#24	7.75	15.63	7.88
10	4 5-1/2	14.94	2	#32	9.25	17.44	8.19
12	5-1/2 7	17.19	2-1/2	#32	10.44	19.75	9.31
14	7 9	19.50	2-1/2	#32	10.69	21.50	10.81
16	9 10	23.38	3	#32	11.63	23.88	12.25

### WM24 3000 PSI

BORE	ROD	E	BSP or NPT	SAE	P*	ZF*	S
3	1-3/4 2	5.19	1/2	#8	5.38	10.50	5.13
4	2 2-1/2	6.50	3/4	#12	5.75	10.19	5.18
5	2-1/2 3-1/2	7.88	3/4	#12	7.00	13.75	6.75
6	3 4	9.25	1	#16	7.94	15.56	7.63
7	3-1/2 5	10.75	1-1/4	#20	8.63	17.38	8.75
8	4 5-1/2	12.38	1-1/2	#24	10.25	20.19	9.94
10	5 7	14.94	2	#32	10.50	21.94	11.94
12	5-1/2 8	17.50	2-1/2	#32	11.44	24.38	13.06
14	7 9	20.38	2-1/2	#32	11.56	25.75	14.19
16	9 10	23.38	3	#32	12.50	29.25	16.75

\*Add stroke to these dimensions

All dimensions in inches

# Rod End Selection

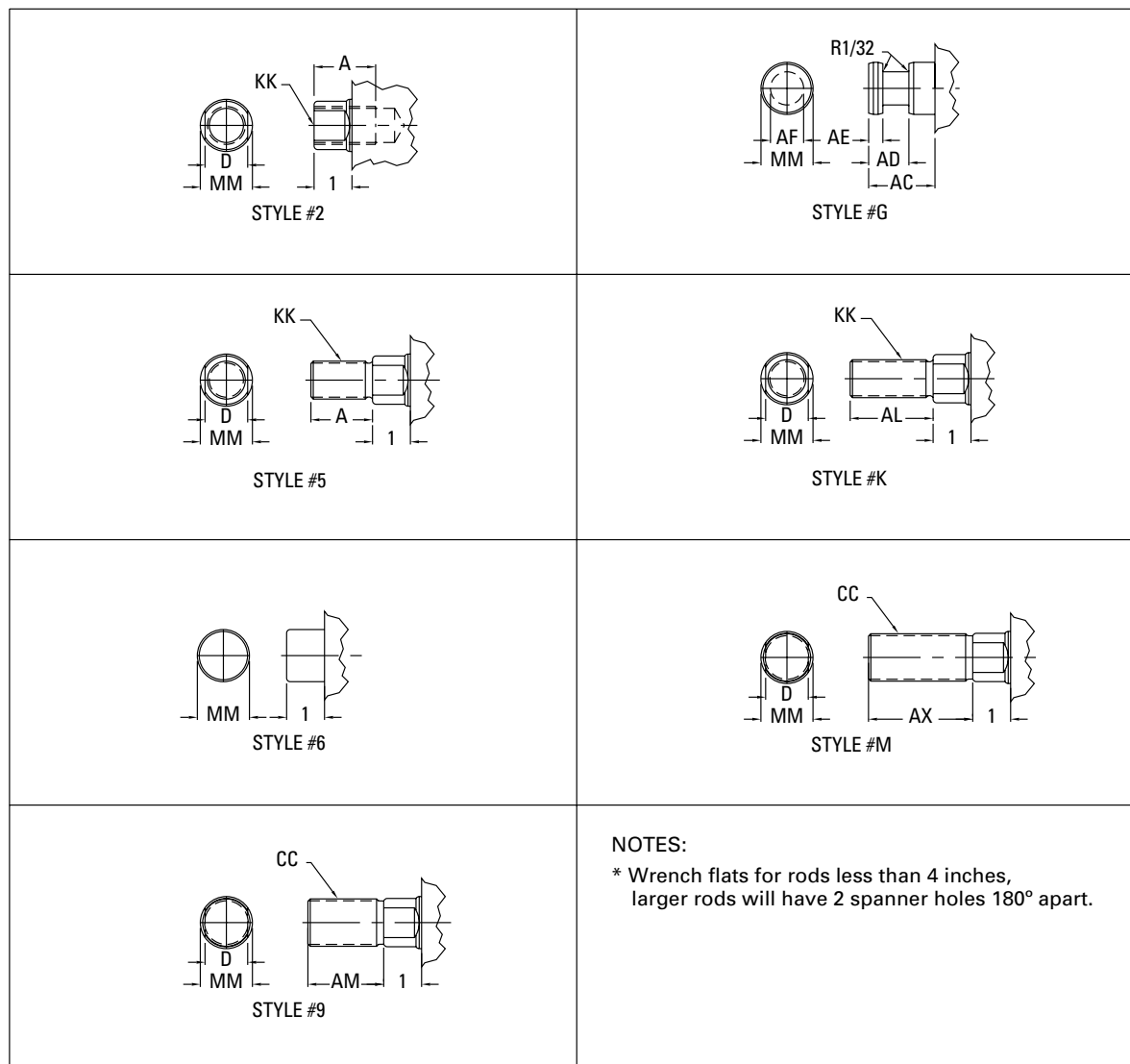

**NOTES:**

\* Wrench flats for rods less than 4 inches, larger rods will have 2 spanner holes 180° apart.

MM	A	AC	AD	AE	AF	AL	AM	AX	CC	D*	KK
1	1.13	1.50	.94	.375	.688	1.56	1.50	1.94	.875-14	.875	.750-16
1.375	1.63	1.75	1.06	.375	.875	2.19	2.00	2.75	1.250-12	1.125	1.000-14
1.75	2.00	1.75	1.31	.500	1.125	2.75	2.25	3.13	1.500-12	1.500	1.250-12
2	2.25	2.63	1.69	.625	1.375	3.13	3.00	4.13	1.750-12	1.688	1.500-12
2.5	3.00	3.25	1.94	.750	1.750	4.13	3.50	4.75	2.250-12	2.062	1.875-12
3	3.50	3.63	2.44	.875	2.250	4.75	3.50	5.50	2.750-12	2.625	2.250-12
3.5	3.50	4.38	2.69	1.000	2.500	5.00	4.50	6.38	3.250-12	3.000	2.500-12
4	4.00	4.50	2.69	1.000	3.000	5.63	4.50	6.56	3.750-12	*	3.000-12
4.5	4.50	4.50	2.69	1.000	3.000	6.38	5.00	7.31	3.750-12	*	3.250-12
5	5.00	5.38	3.19	1.500	3.875	7.00	5.00	7.56	4.750-12	*	3.500-12
5.5	5.50	6.25	3.94	1.875	4.375	7.75	6.75	9.56	5.250-12	*	4.000-12
7	7.00	6.50	4.06	2.000	5.750	10.00	7.00	10.50	6.500-12	*	5.500-12
8	8.00	6.50	4.06	2.000	6.500	11.25	8.00	12.00	7.500-12	*	6.000-12
9	9.00	6.75	4.13	2.000	7.250	12.50	9.00	13.50	8.500-12	*	6.500-12
10	10.00	7.25	4.63	2.375	8.000	14.00	10.00	15.13	9.500-12	*	7.250-12

# Mounting Accessories

## Swivel Pin

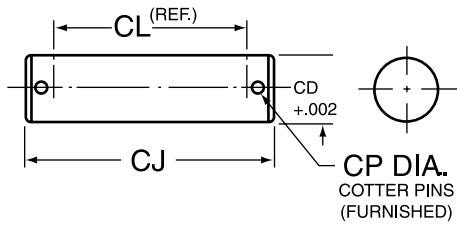

- Swivel pins are furnished with clevis mounted cylinders.
- Swivel pins must be ordered as a separate item if to be used with female eye, female clevis, standard eye bracket and clevis bracket. They are included only with swivel eye bracket.

Part No.	CD	CJ	CL	CP
WM83075-10	.750	3.25	2.5	.188
WM83125-10	1.250	3.75	3	.188
WM83137-10	1.375	4.00	3.25	.188
WM83150-10	1.500	4.75	3.75	.25
WM83175-10	1.750	5.50	4.5	.25
WM83200-10	2.000	7.00	6	.25
WM83250-10	2.500	8.00	7	.25
WM83300-10	3.000	10.50	9	.375
WM83350-10	3.500	11.50	10	.375
WM83425-10	4.250	13.50	12	.375

## Rod Eye

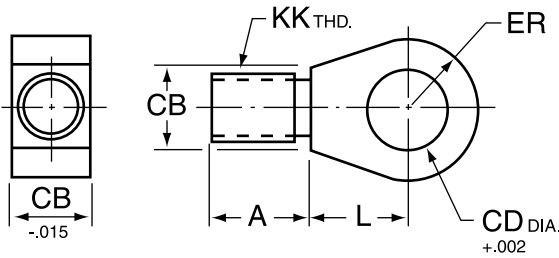

Part No.	A	CB	CD	ER	KK	L
WM60075	.88	1.25	.752	.63	.750-16	.88
WM60125	1.25	1.50	1.252	1.13	1.000-14	1.38
WM60137	1.63	2.00	1.377	1.25	1.250-12	1.50
WM60150	1.88	2.25	1.502	1.38	1.500-12	1.68
WM60175	2.38	2.75	1.752	1.63	1.875-12	1.88
WM60200	2.88	3.25	2.002	1.88	2.250-12	2.13
WM60250	3.38	3.75	2.502	2.38	2.500-12	2.63
WM60300	4.00	4.50	3.002	2.88	3.000-12	3.13
WM60350	5.50	6.00	3.502	3.38	4.000-12	3.63
WM60425	6.50	7.50	4.252	4.00	5.000-12	4.25

## Eye Bracket

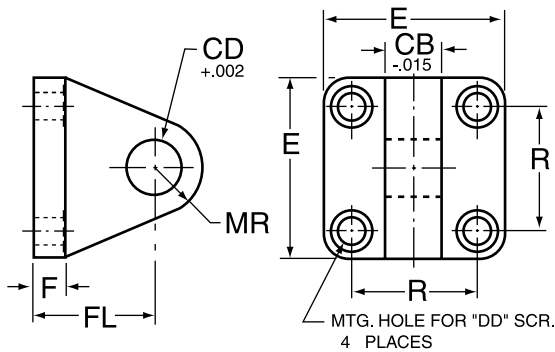

Part No.	CB	CD	DD	E	F	FL	MR	R
WM78075	1.00	.752	.38	3.00	.56	1.75	.63	2.25
WM78125	1.25	1.252	.63	5.00	.94	3.00	1.13	3.75
WM78137	1.25	1.377	.75	6.00	1.19	3.88	1.25	4.50
WM78150	1.25	1.502	1.00	7.00	1.44	4.63	1.38	5.00
WM78175	1.50	1.752	1.25	8.25	11.06	5.63	1.63	6.00
WM78200	3.00	2.002	1.50	10.00	11.31	6.88	1.88	7.25
WM78250	3.50	2.502	1.75	13.25	2.19	8.75	2.38	10.00
WM78300	4.50	3.002	2.00	15.75	2.44	10.25	2.88	12.00
WM78350	5.00	3.502	2.00	18.00	2.44	11.25	3.38	14.25
WM78425	6.00	4.252	2.50	20.50	2.94	12.50	4.00	16.00

## Rod Clevis

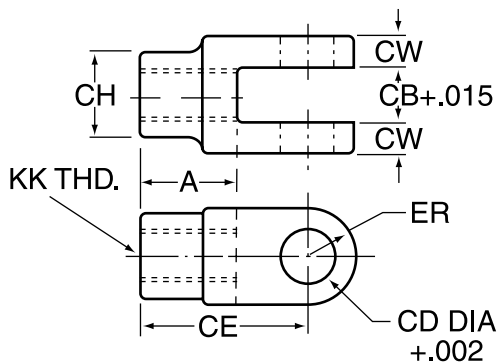

Part No.	A	CB	CD	CE	CH	CW	ER	KK
WM62075	1.13	1.00	.752	2.00	1.13	.75	.63	.750-16
WM62125	1.50	1.25	1.252	2.88	2.00	.88	1.13	1.000-14
WM62137	1.88	1.25	1.377	3.38	2.25	1.00	1.25	1.250-12
WM62150	2.13	1.25	1.502	3.75	2.50	1.25	1.38	1.500-12
WM62175	2.63	1.50	1.752	4.50	3.00	1.50	1.63	1.875-12
WM62200	3.13	3.00	2.002	5.25	3.50	1.50	1.88	2.250-12
WM62250	3.63	3.50	2.502	6.25	4.00	1.75	2.38	2.500-12
WM62300	4.38	4.50	3.002	7.50	5.00	2.25	2.88	3.000-12
WM62350	5.88	5.00	3.502	9.50	6.00	2.50	3.38	4.000-12
WM62425	7.25	6.00	4.252	11.50	7.50	3.00	4.00	5.000-12

## Notes

---

14615 Lone Oak Road  
Eden Prairie, MN 55344  
USA  
tel: 952 937-9800  
fax: 952 974-7722  
[www.hydraulics.eaton.com](http://www.hydraulics.eaton.com)

2425 W. Michigan Avenue  
Jackson, MI 49202  
USA  
tel: 517 787-7220  
fax: 517 787-3450

7638 Pacific Avenue  
White City, OR 97503-1091  
USA  
tel: 541 826-2131  
fax: 541 826-3344

1112 Brooks Street S.E.  
Decatur, AL 35601  
USA  
tel: 256 350-2339  
fax: 256 351-9224



© 2002 Eaton Corporation  
All Rights Reserved  
Printed in USA  
Document No. V-CC-MC-0001-E

April, 2002 5M